

Jun.1.2022 Copyright 2022 HIROSE ELECTRIC CO., LTD. All Rights Reserved.  
In case of consideration for using Automotive equipment / device which demand high reliability, kindly contact our sales window correspondents.

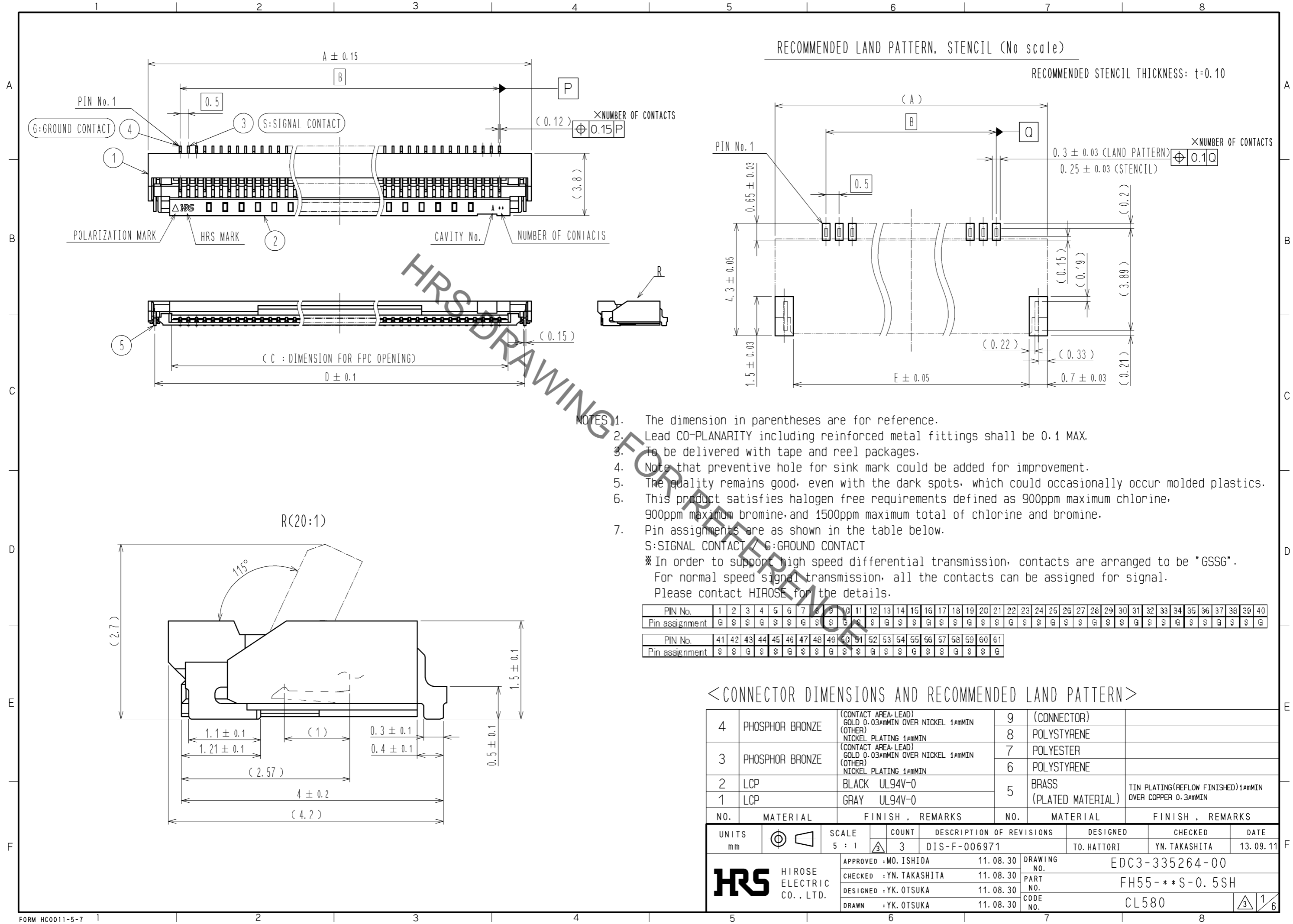

- NOTES
- The dimension in parentheses are for reference.
  - Lead CO-PLANARITY including reinforced metal fittings shall be 0.1 MAX.
  - To be delivered with tape and reel packages.
  - Note that preventive hole for sink mark could be added for improvement.
  - The quality remains good, even with the dark spots, which could occasionally occur molded plastics.
  - This product satisfies halogen free requirements defined as 900ppm maximum chlorine, 900ppm maximum bromine, and 1500ppm maximum total of chlorine and bromine.
  - Pin assignments are as shown in the table below.  
S: SIGNAL CONTACT / G: GROUND CONTACT  
\*In order to support high speed differential transmission, contacts are arranged to be "GSSG".  
For normal speed signal transmission, all the contacts can be assigned for signal.  
Please contact HIROSE for the details.

PIN No.	1	2	3	4	5	6	7	8	9	10	11	12	13	14	15	16	17	18	19	20	21	22	23	24	25	26	27	28	29	30	31	32	33	34	35	36	37	38	39	40	
Pin assignment	G	S	S	G	S	S	S	S	G	S	S	S	S	S	S	S	S	S	S	G	S	S	G	S	S	S	S	S	S	G	S	S	S	G	S	S	G	S	S	S	G
PIN No.	41	42	43	44	45	46	47	48	49	50	51	52	53	54	55	56	57	58	59	60	61																				
Pin assignment	S	S	G	S	S	G	S	S	G	S	S	G	S	S	G	S	S	G	S	S	G																				

<CONNECTOR DIMENSIONS AND RECOMMENDED LAND PATTERN>

4	PHOSPHOR BRONZE	(CONTACT AREA-LEAD) GOLD 0.03#MIN OVER NICKEL 1#MIN (OTHER) NICKEL PLATING 1#MIN	9	(CONNECTOR)	
3	PHOSPHOR BRONZE	(CONTACT AREA-LEAD) GOLD 0.03#MIN OVER NICKEL 1#MIN (OTHER) NICKEL PLATING 1#MIN	8	POLYSTYRENE	
2	LCP	BLACK UL94V-0	7	POLYESTER	
1	LCP	GRAY UL94V-0	6	POLYSTYRENE	
			5	BRASS (PLATED MATERIAL)	TIN PLATING(REFLOW FINISHED)1#MIN OVER COPPER 0.3#MIN
NO.	MATERIAL	FINISH . REMARKS	NO.	MATERIAL	FINISH . REMARKS

UNITS mm		SCALE 5 : 1	COUNT 3	DESCRIPTION OF REVISIONS DIS-F-006971	DESIGNED TO. HATTORI	CHECKED YN. TAKASHITA	DATE 13. 09. 11
<b>HRS</b> HIROSE ELECTRIC CO., LTD.		APPROVED : MO. ISHIDA	11. 08. 30	DRAWING NO. EDC3-335264-00			
		CHECKED : YN. TAKASHITA	11. 08. 30	PART NO. FH55-**S-0.5SH			
		DESIGNED : YK. OTSUKA	11. 08. 30	CODE NO. CL580			
		DRAWN : YK. OTSUKA	11. 08. 30				

Jun.1.2022 Copyright 2022 HIROSE ELECTRIC CO., LTD. All Rights Reserved.  
In case of consideration for using Automotive equipment / device which demand high reliability, kindly contact our sales window correspondents.

RECOMMENDED FPC (No scale)

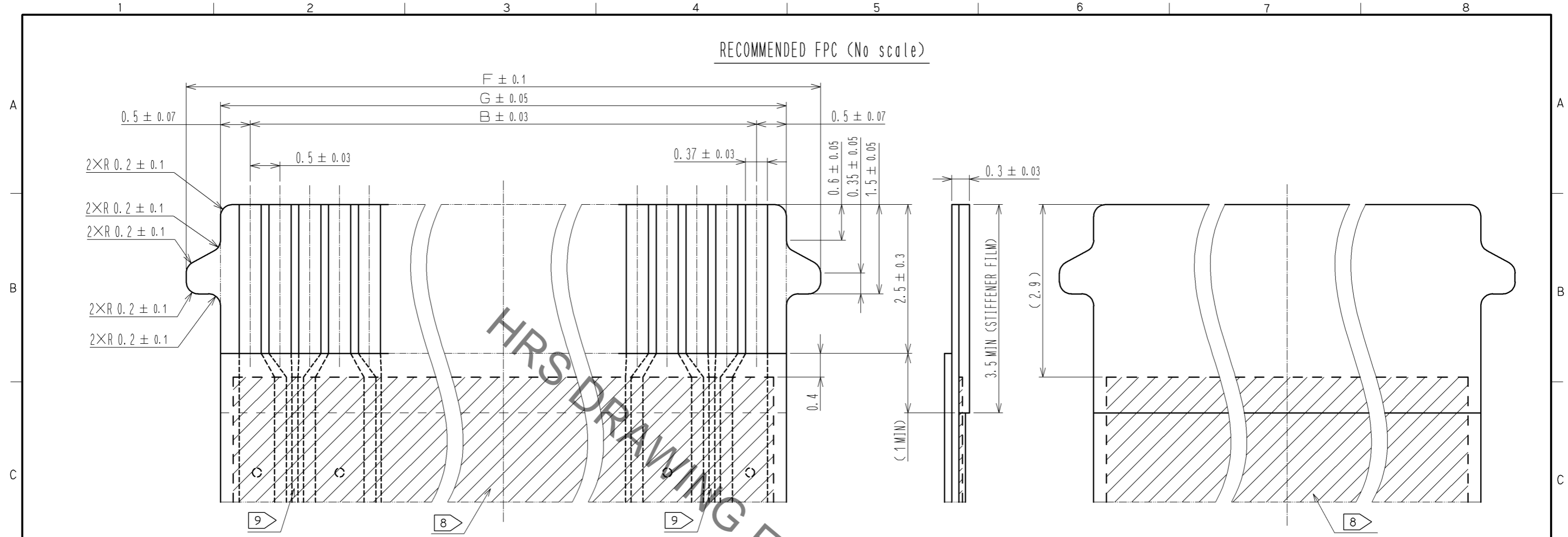

10 FPC CONFIGURATION (Reference example)

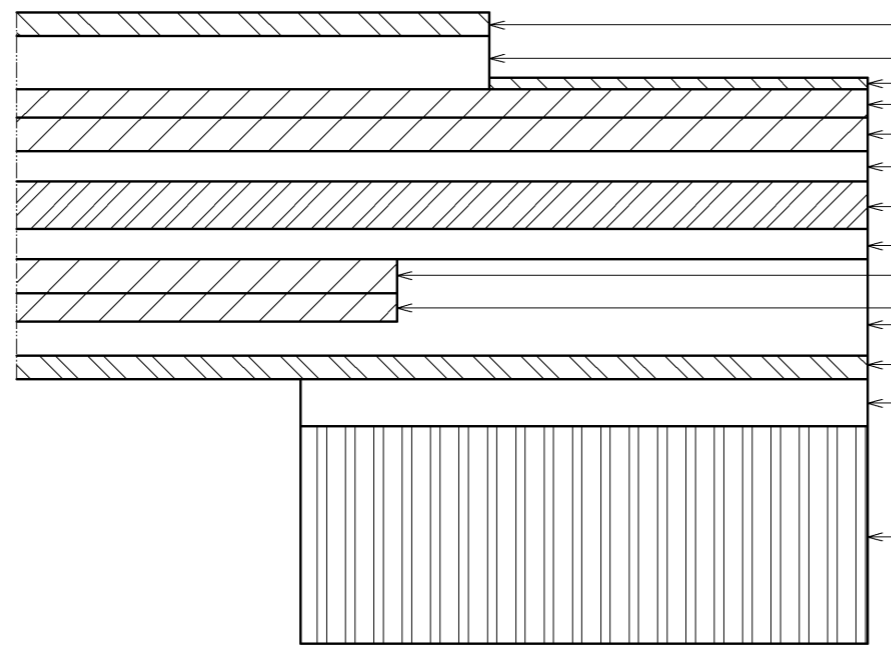

Material	Thickness (μm)		
	LCP 2-Layer CCL	Polyimide 2-Layer CCL	Polyimide 3-Layer CCL
① Cover Lay Film	12.5	12.5	12.5
② Cover Adhesive	28	28	28
③ Surface Treatment (Nickel Under Plating + Gold Plating)	(6)	(6)	(6)
④ Copper Plating (Through Hole Copper)	15	15	15
⑤ Pattern Copper Foil	9	18	18
⑥ Base Adhesive (Thermoset Adhesive)	-	-	16
⑦ Base Film <11>	50	25	25
⑧ Base Adhesive (Thermoset Adhesive)	-	-	16
⑨ Ground Copper Foil	9	18	18
⑩ Copper Plating (Through Hole Copper)	15	15	15
⑪ Cover Adhesive (Thermoset Adhesive)	28	28	28
⑫ Cover Lay Film	12.5	12.5	12.5
⑬ Stiffener Adhesive (Thermoset Adhesive)	50	50	30
⑭ Stiffener Film	125	150	125
Total of Mating Area (③ to ⑧, ⑫ to ⑭)	295.5	304.5	291.5

- NOTES
- 8 This shaded area is ground copper foil.
  - 9 Match the impedance to your system conditions.
  - 10 FPC Configuration example is for reference. Applicable FPC mating area thickness is 0.3±0.03mm.
  - 11 This is reference examples of base film material. LCP means liquid crystalline polymer.

<RECOMMENDED FPC>

<b>HRS</b>	DRAWING NO.	EDC3-335264-00
	PART NO.	FH55-**-S-0.5SH
	CODE NO.	CL580

Jun.1.2022 Copyright 2022 HIROSE ELECTRIC CO., LTD. All Rights Reserved.  
 In case of consideration for using Automotive equipment / device which demand high reliability, kindly contact our sales window correspondents.

EMBOSSED CARRIER TAPE DIMENSION (2:1)

REEL DIMENSIONS (No Scale)

TAPE WIDTH : 24mm MAX

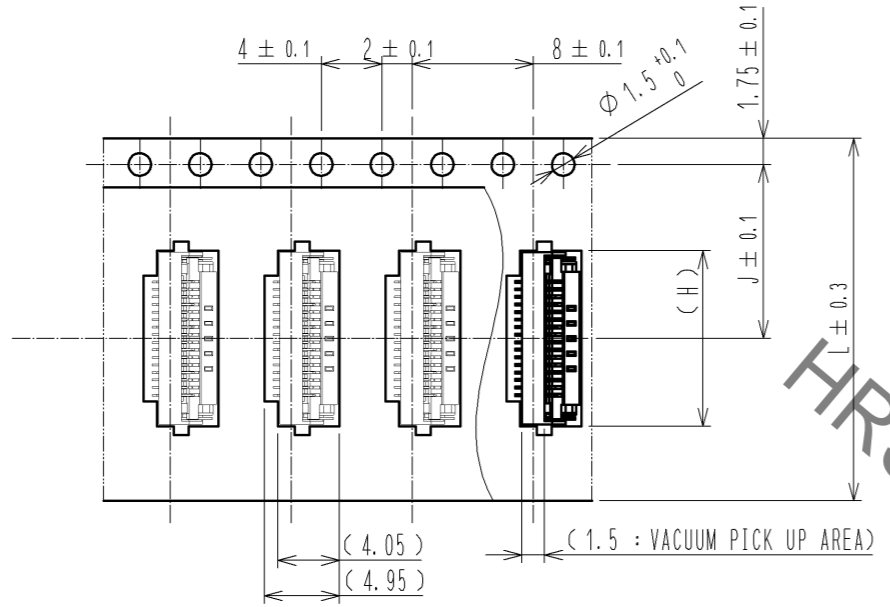

DIRECTION OF UNREELING

TAPE WIDTH : 32mm MIN

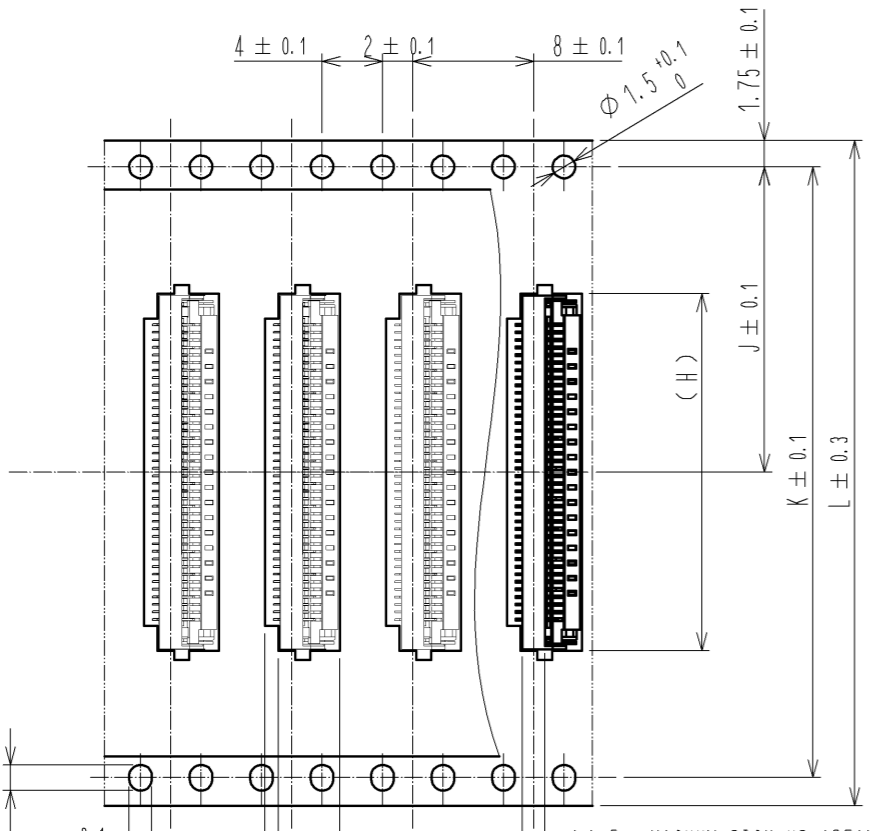

DIRECTION OF UNREELING

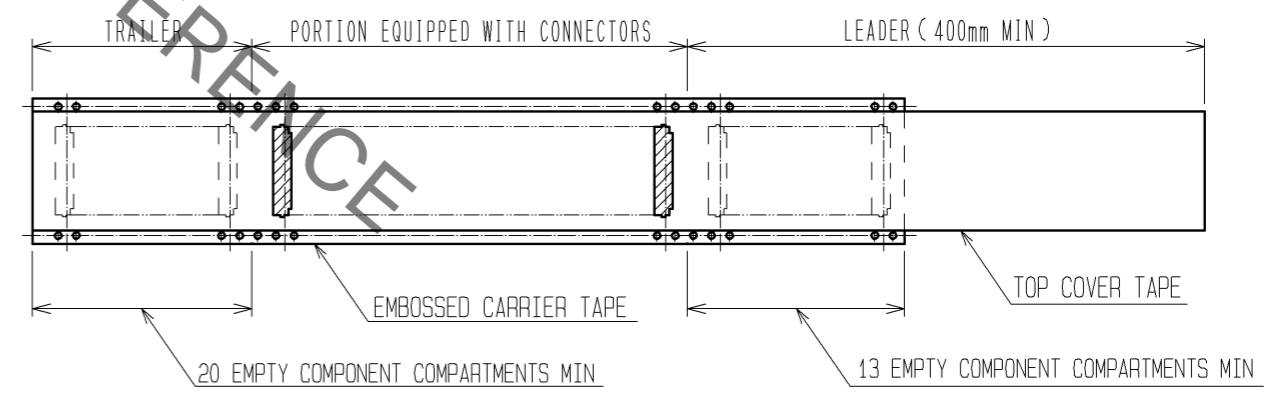
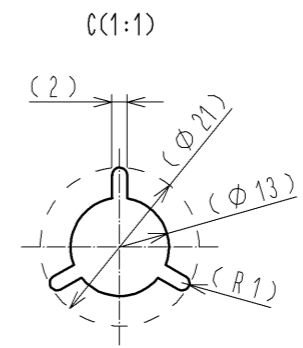
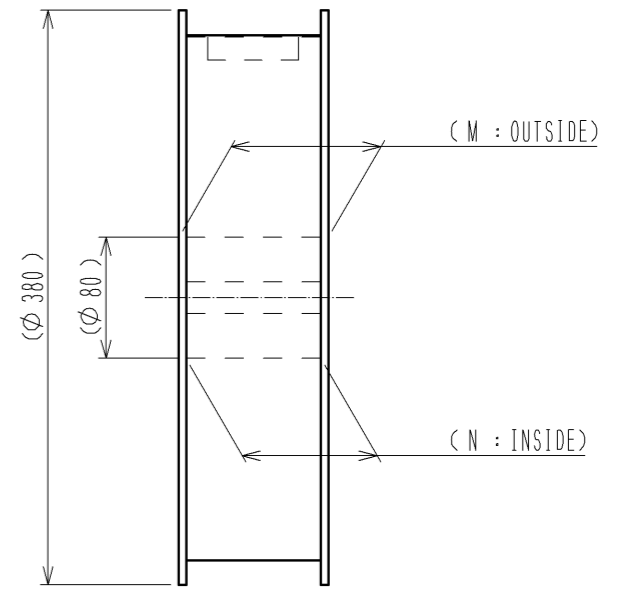
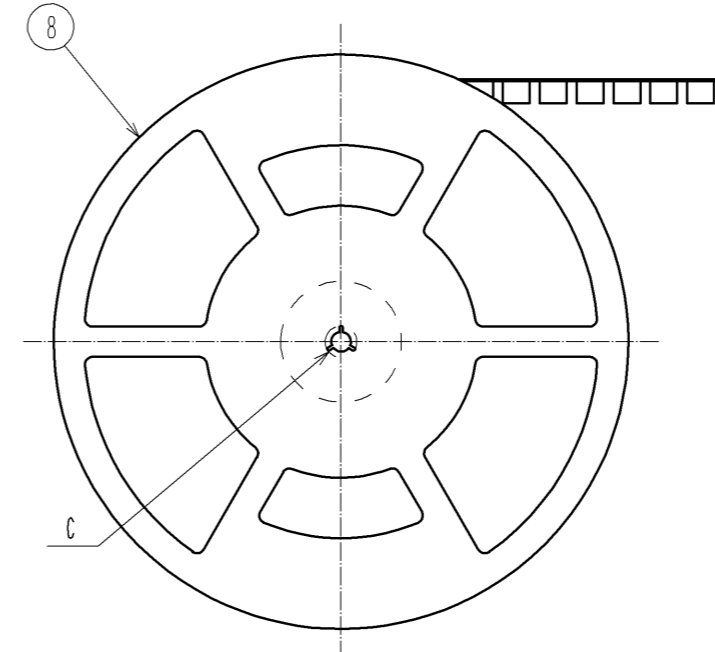
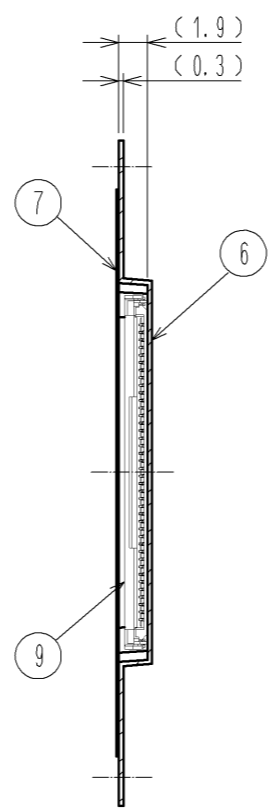
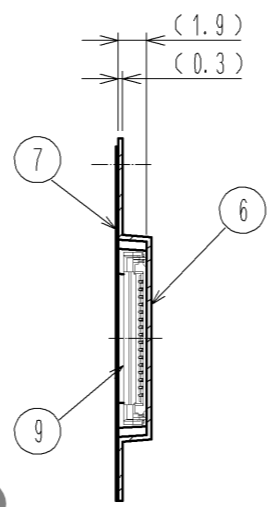

- NOTES 12. 1 reel : 5000 connectors.  
 13. Refer to JIS C 0806. (Packaging of components for automatic handling.)

<DRAWING FOR PACKING>

<b>HRS</b>	DRAWING NO.	EDC3-335264-00
	PART NO.	FH55-**S-0.5SH
	CODE NO.	CL580
		3/6

Jun.1.2022 Copyright 2022 HIROSE ELECTRIC CO., LTD. All Rights Reserved.  
 In case of consideration for using Automotive equipment / device which demand high reliability, kindly contact our sales window correspondents.

PART No.	CODE No.	NUMBER OF CONTACTS			DIMENSION OF CONNECTOR, LAND PATTERN, STENCIL AND FPC							DIMENSION OF DRAWING FOR PACKING					
		TOTAL	SIGNAL CONTACT	GROUND CONTACT	A	B	C	D	E	F	G	H	J	K	L	M	N
FH55-10S-0.5SH	-	10	6	4	8.4	4.5	5.57	7.59	7.0	6.65	5.5	8.6	11.5	—	24	29.4	25.4
FH55-22S-0.5SH	CL580-3707-7-00	22	14	8	14.4	10.5	11.57	13.59	13.0	12.65	11.5	14.6	11.5	—	24	29.4	25.4
FH55-31S-0.5SH	CL580-3704-9-00	31	20	11	18.9	15.0	16.07	18.09	17.5	17.15	16.0	19.1	14.2	28.4	32	37.4	33.4
FH55-40S-0.5SH	CL580-3700-8-00	40	26	14	23.4	19.5	20.57	22.59	22.0	21.65	20.5	23.6	20.2	40.4	44	49.4	45.4
FH55-49S-0.5SH	-	49	32	17	27.9	24.0	25.07	27.09	26.5	26.15	25.0	28.1	20.2	40.4	44	49.4	45.4
FH55-61S-0.5SH	-	61	40	21	33.9	30.0	31.07	33.09	32.5	32.15	31.0	34.1	26.2	52.4	56	61.4	57.4

※CONTACT POSITIONS WITHOUT CODE NUMBERS ARE CURRENTLY UNDER PLANNING.  
 PLEASE CONTACT HIROSE FOR DETAILED INFORMATION ABOUT PRODUCT VARIATION.

HRS DRAWING FOR REFERENCE

△ < TABLE OF DIMENDIONS >

HRS	DRAWING NO.	EDC3-335264-00
	PART NO.	FH55-***S-0.5SH
	CODE NO.	CL580

△ 4/6

Jun.1.2022 Copyright 2022 HIROSE ELECTRIC CO., LTD. All Rights Reserved.  
In case of consideration for using Automotive equipment / device which demand high reliability, kindly contact our sales window correspondents.

This connector requires delicate and careful handling.  
Read through the instructions shown below and handle the connector properly.  
Each values indicating here are for reference and may differ from standard value.

[INSTRUCTIONS FOR MOUNTING ON THE BOARD]

◆ Warp of Board

Minimize warp of the Board as much as possible.  
Lead co-planarity including reinforced metal fittings is 0.1 mm or less.  
Too much warp of the Board may result in a soldering failure.

◆ Load to Connector

Do not add 1N or greater external force when unreel or pick and place the connector etc.  
or it may get broken.  
In addition, do not insert the FPC or operate the connector before mounting it.

◆ Load to Board

Splitting a large Board into several pieces  
Screwing the Board  
Avoid the handling described above so that no force is exerted on the Board during the assembly process.  
Otherwise, the connector may become defective.

◆ Amount of Warp

The warp of a 100mm wide Board should be 1 mm or less.  
The warp of Board suffers stress on connector and the connector may become defective.

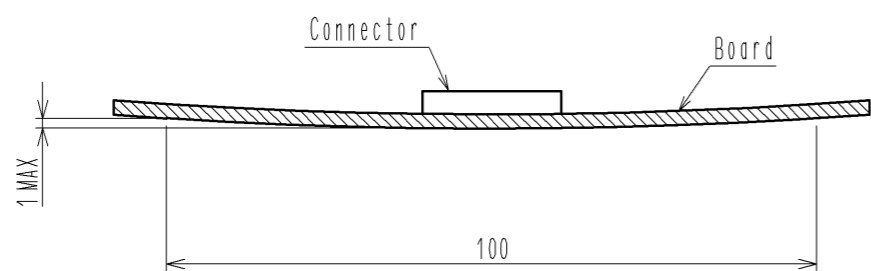
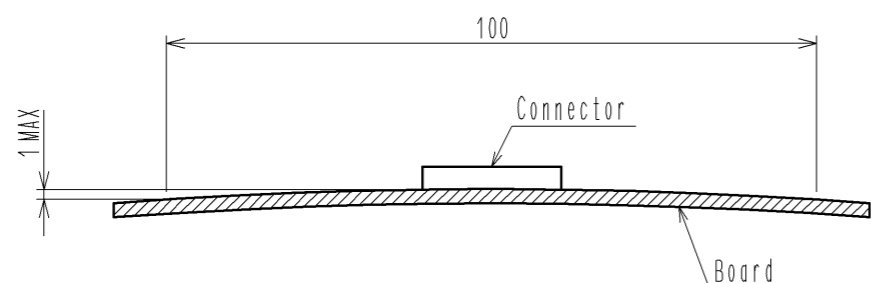

[INSTRUCTIONS ON INSERTING FPC AND CONNECTION]

◆ Use of the Actuator

1. Be very careful not to apply excessive force when releasing the actuator in the initial position.  
If you use your nail or finger as shown below, the terminals may be deformed.

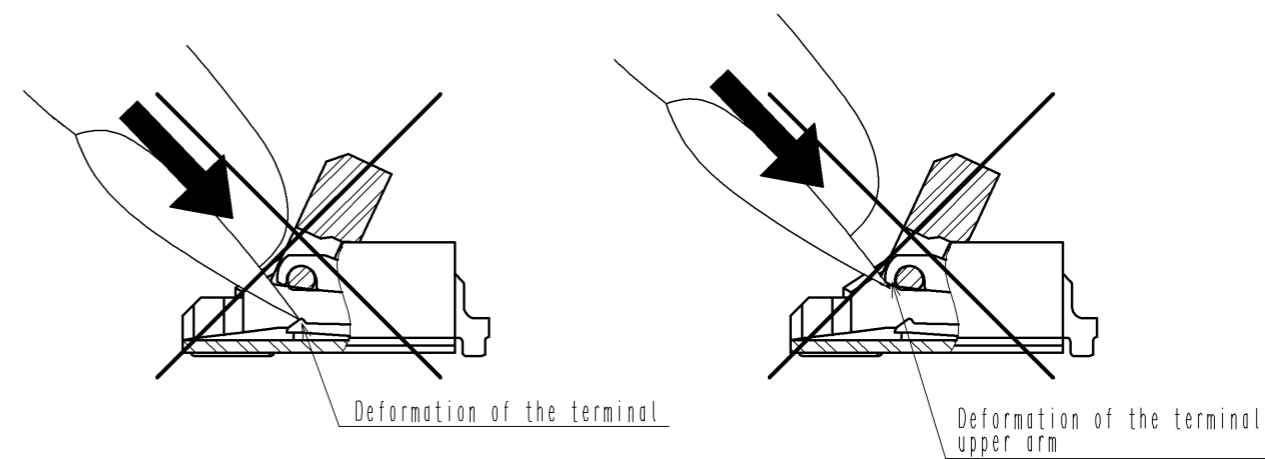

2. The actuator rotates around the rotational axis as shown below.  
Rotate the actuator.
3. The actuator will not open more than 115°.  
Do not apply any force backward beyond this point.  
Otherwise, the actuator may come off or break.

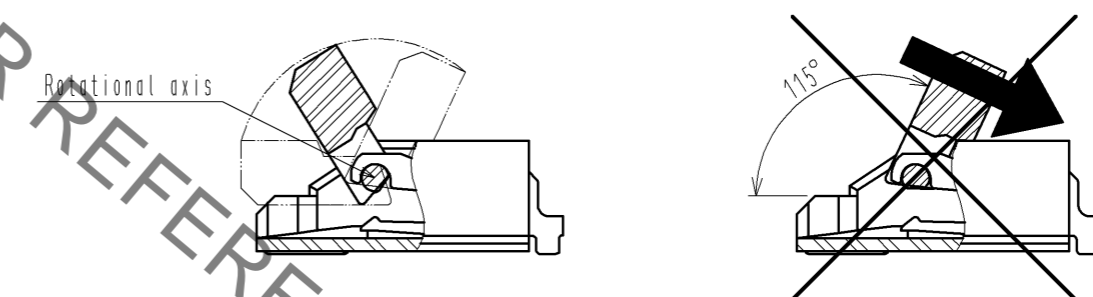

4. Move the actuator at approximately the center.
5. Do not pinch or pick the actuator to lift it as shown below. Otherwise, it may break.  
(Do not carry out any operation other than rotating the actuator as shown in 2 above.)

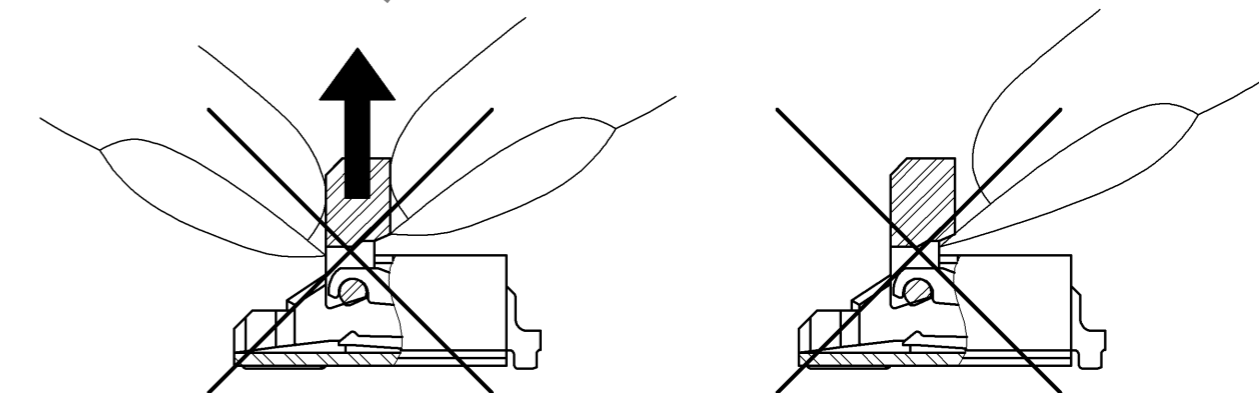

<INSTRUCTION MANUAL(1)>

<b>HRS</b>	DRAWING NO.	EDC3-335264-00
	PART NO.	FH55-***S-0.5SH
	CODE NO.	CL580
		3/5/6

Jun.1.2022 Copyright 2022 HIROSE ELECTRIC CO., LTD. All Rights Reserved.  
In case of consideration for using Automotive equipment / device which demand high reliability, kindly contact our sales window correspondents.

◆ Direction of Contacts

This connector has contacts on the bottom. Thus, insert FPC with the exposed conductors face down.

◆ Inserting the FPC

1. Insert the FPC by about 12 degrees along the surface and at a right angle to the connector.  
Insert it properly to the very end.

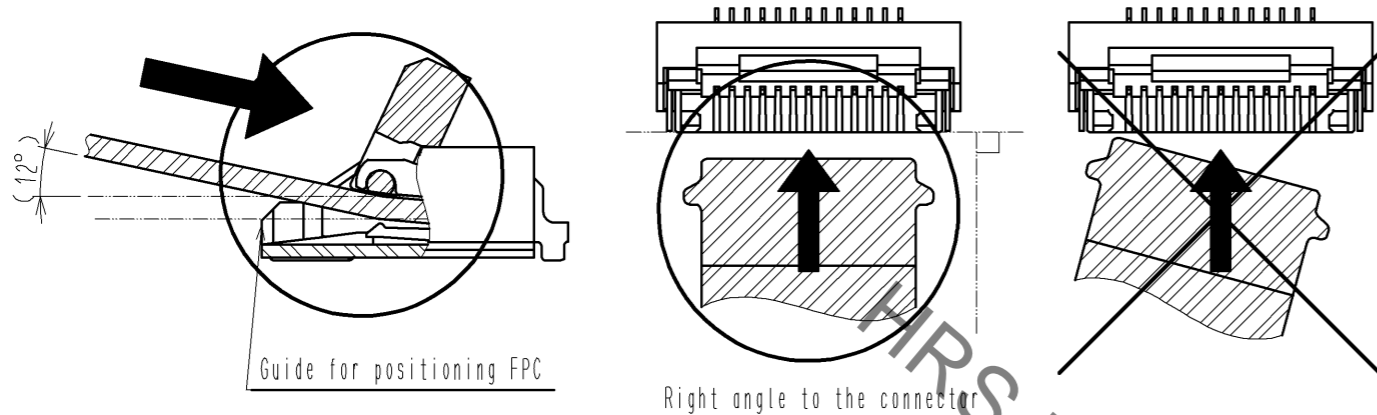

2. Do not insert the FPC diagonally from above.  
If the FPC is inserted at a slant (incorrectly) as shown below in the FPC insertion process, the edge of the FPC may catch in the terminals, resulting in deformation of the terminals. The FPC may bend and patterns may break or the FPC may not insert completely, resulting in improper conduction.

※ Keep a sufficient FPC insertion space in the stage of the layout in order to avoid incorrect FPC insertion.

Besides, it is not difficult to insert FPC correctly all the way to the end. Design the proper layout of parts.

※ Make adjustments with the FPC manufacturer for FPC bending performance and wire breakage.

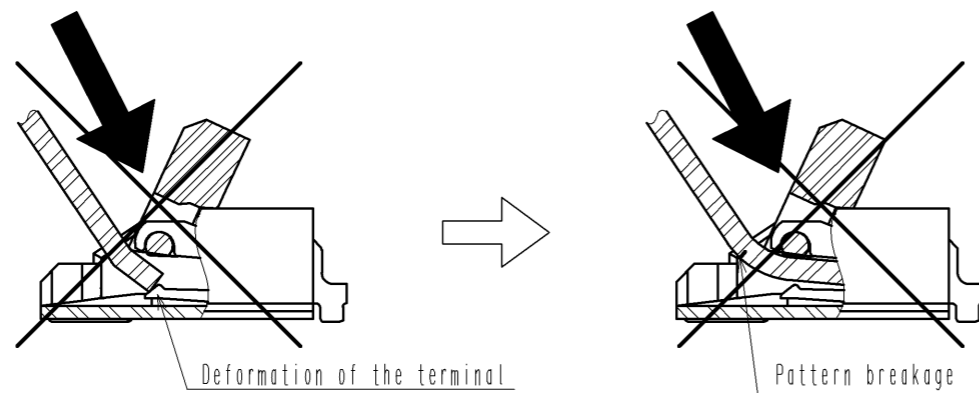

3. Do not rotate the actuator when FPC TAB is on right and left guides for positioning FPC.  
Make sure the position of FPC TAB and guides before rotate the actuator.

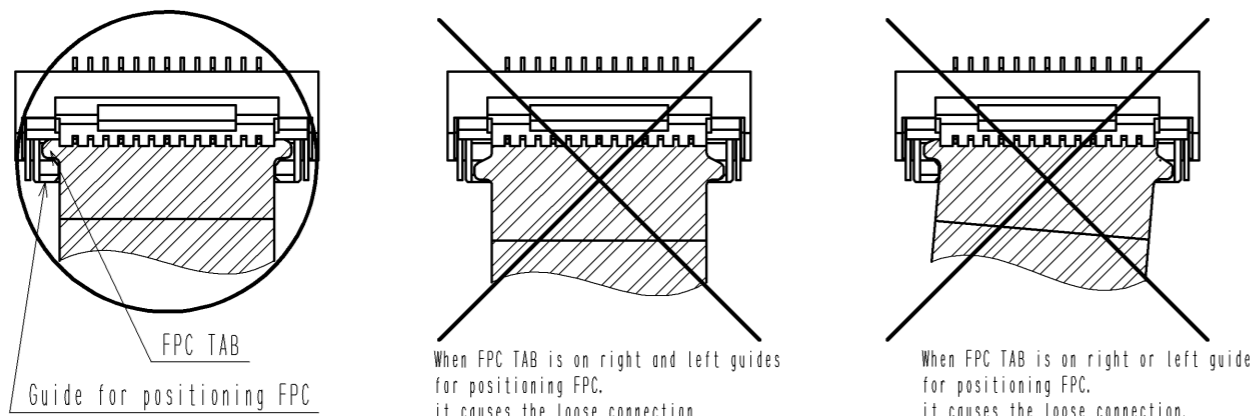

◆ Checking the Locking Condition

In the locked condition, make sure that the actuator is horizontal on the Board surface. Do not apply excessive force to it near the 0° position of the actuator. Otherwise, the terminals may be deformed.

[INSTRUCTIONS ON FPC LAYOUT AFTER CONNECTION]

◆ Load to FPC

Be very careful not to apply any force to the connector directly after inserting FPC. Otherwise, the connector may become unlocked or the FPC may break. In particular, design the FPC layout with care not to bend it sharply upward in a vertical direction near the insertion opening. Fix the FPC when loads are applied to it continuously.

Load:  $0.05 \times n$  N MAX  
(n: number of contacts)

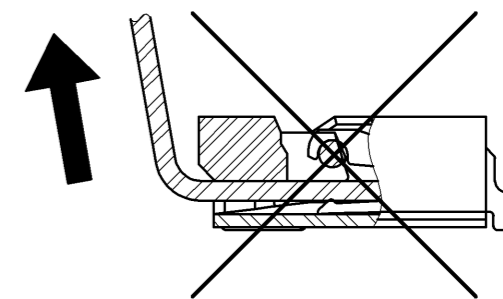

[INSTRUCTIONS ON REMOVING FPC]

◆ Move the actuator at approximately the center.

◆ Release the actuator to remove the FPC.  
Remove the FPC by about 12 degrees along the surface.

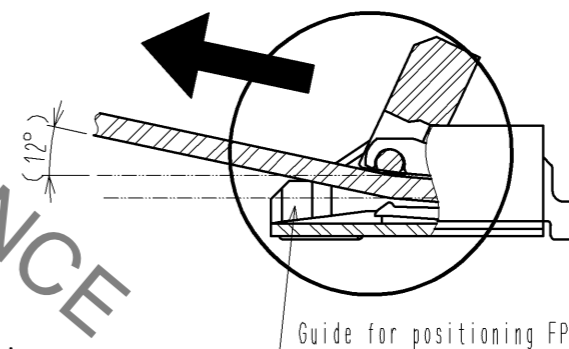

[OTHER INSTRUCTIONS]

◆ Instructions on Manual Soldering

Follow the instructions shown below when soldering the connector manually during repair work, etc.

1. Do not perform reflow soldering or manual soldering with the FPC inserted into the connector.
2. Do not heat the connector excessively. Be very careful not to let the soldering iron contact any parts other than connector leads. Otherwise, the connector may be deformed or melt.
3. Do not use excessive solder (or flux).  
If excessive solder (or flux) is used on the terminals, solder or flux may adhere to the contacts or rotating parts of the actuator, resulting in poor contact or a rotation failure of the actuator. Supplying excessive solder to the reinforcing bracket may hinder actuator rotation, resulting in breakage of the connector.

<INSTRUCTION MANUAL(2)>

<b>HRS</b>	DRAWING NO.	EDC3-335264-00
	PART NO.	FH55-**-S-0.5SH
	CODE NO.	CL580